

全自动除尘吸料机 (免人工清理)

AUTOMATIC DUST COLLECTOR (NO MANUAL CLEANING)

螺杆上料机

SCREW FEEDER

免清洗吸料机优点:

1. 350一体式设计, 950/960主机与料斗分体设计。安全、简便、输送顺畅。
2. 采用纳米无纺布过滤, 搭配控制器清网功能, 实现自动电子脉冲除尘功能。950/960配备压缩储气罐, 反吹更强劲, 运转更稳定, 有效的无需人工清尘工作。
3. 主机电机无粉末, 不易损坏。
4. 无粉末排除, 车间干净、整洁又环保。

适用于颗粒新料、色母料、破碎回收料、流动性较好的物料, 也适用于在颗粒加色粉原料及破碎过程中产生大量粉末搅拌的物料。(不适用于外加超过20%以上的粉末或全粉料)

Advantages of no cleaning suction machine:

1. 350 integrated design, 950 / 960 main engine and hopper separated design. It is safe, simple and easy to transport.
2. It adopts nano non-woven fabric filtration, with the net clearing function of the controller, to realize the automatic electronic pulse dust removal function. The 950 / 960 is equipped with a compressed air storage tank, with stronger back blowing, more stable operation, and effective dust free operation.
3. The main motor is free of powder and is not easy to be damaged.
4. No powder is removed, and the workshop is clean, clean and environmental friendly.

It is suitable for new granular materials, color masterbatch, broken recycled materials, materials with good fluidity, as well as materials with large amount of powder mixing in the process of granular coloring powder raw materials and crushing. (not suitable for addition of more than 20% powder or all powder)



950/960型除尘
950 / 960 dedusting type



350型除尘
350 type dust removal



耐高温油过滤器
Temperature and oil resistant filter



技术参数 TECHNICAL PARAMETER

型号MODEL	除尘(Remove dust)350	除尘欧化(european remove dust)950	除尘欧化(european remove dust)960
马达形式 Motor form	碳刷式(Carbon brush)220v	感应式(Induction)380V	感应式(Induction)380V
功率Power	1.2KW	1.8KW	2.2KW
输送能力Conveying capacity	300kg/hrr	400kg/hrr	500kg/hrr
滤清器Filter	M185*90H	M188*115H	M188*115H
储料桶容量Bucket capacity	15L	15L	15L
输料管内径 Feed pipe	M38mm	M38mm	M38mm
外形尺寸 Dimension	350mm*330mm*680mm	450mm*430mm*1020m	450mm*430mm*1020mm
主体重量Weight	25kg	50kg	52kg

产品规格参数如有变动, 恕不另行通知。
Specifications are subject to change without notice.



特点 >>

- 采用不锈钢制造, 输送管、中心主轴、螺片、料箱均为不锈钢材质, 坚固耐用;
 - 可与各种规格挤出机, 搅拌机配套使用;
 - 适用于各种颗粒状、粉碎料等物料上料输送用途;
 - 配备自动加料控制箱, 可有效降低工人的工作强度, 提高工作效率;
 - 常备Φ102、Φ133、Φ159、Φ219mm等管径规格供客选用, 工作能力为0.5-10 t/h。
- Adopt stainless steel, pipe, central spindle, screw, container for stainless steel material, durable;
 - But with all kinds of extruder, mixer used;
 - Low is suitable for various granular, crushing materials such as material feeding conveying purpose;
 - Equipped with automatic feeding control box, can effectively reduce the working strength of workers, improve work efficiency;
 - Low stock Φ102, Φ133,Φ159,Φ219mm diameter specifications for customer choice, such as the ability to work is 0.5-10 t/h.

螺杆上料机都是量身定制的, 一般需要的尺寸如下螺杆筒直径? 长度? 下料口离地高度?料斗长宽高尺寸? 上什么料?

The screw feeder is tailor-made, and the generally required dimensions are as follows screw barrel diameter? Length? The height of the discharge port from the ground? Hopper length width and height dimensions? What material is loaded?

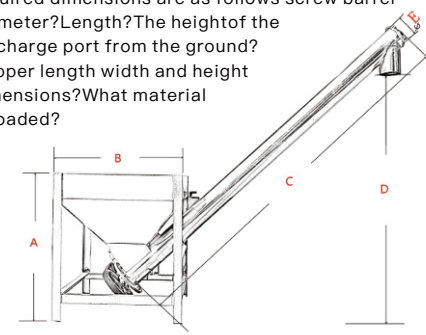

技术参数 TECHNICAL PARAMETER

型号MODEL	C螺杆长度 C Screw length	D垂直高度 D Vertical height	E管径 E Pipe diameter	电机大小 Motor size
800*900*900高 或者700*700*700高 (尽量选这两款标准尺寸) 螺杆标准角度56度 (角度也可根据场地变化)	2	1	114	1.5
	2.4	1.5	114	1.5
	2.7	2	114	1.5
800*900*900 or700*700*700 high (Try to choose these two standard sizes)The standard angle of the screw is 56 degrees(the angle can also be changed according to the site)	3.5	2.5	114	2.2
	4	3	114	2.2
	4.5	3.5	114	2.2
	5	4	114	2.2
	6	4.5	114	2.2
6.8	5	114	3	

产品规格参数如有变动, 恕不另行通知。
Specifications are subject to change without notice.